

**FLH-1 Bilancino con gancio girevole per carrelli elevatori**

Il bilancino trasforma un carrello elevatore in una gru mobile. È sufficiente serrare i bulloni di sicurezza per fissare il bilancino. Il gancio orientabile provvisto di chiusura di sicurezza garantisce la massima tenuta anche in presenza di vibrazioni.

*Attaching of the balance will change a fork lift to a mobile crane.*

*Only tighten the securing bolts to fix the balance. The latch is attached to the swivel hook for omnidirectional-operation and is vibration proof.*

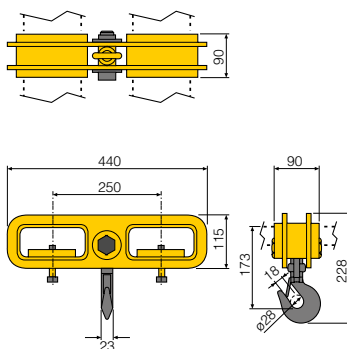

Articolo Article	Codice Code	Portata Kg Capacity Kg	Dimensioni mm - Dimensions mm		Peso Kg Weight Kg	
			Larghezza - Width	Spessore - Thickness		
FLH-1	179881	<b>1000</b>	70 - 120	15 - 40	12,0	1
FLH-2 ⚠	222112	<b>2000</b>	120 - 150	38 - 65	24,0	1

\* Portate differenti disponibili a richiesta